



# FY17 MID-TERM BUSINESS PLAN EVALUATION



# PROGRAM LINES OF BUSINESS

PLOB 1			PLOB 2			PLOB 3		
Community Development			Housing Market Development			Housing & Social Development		
<b>NB</b>	<b>RL</b>	<b>HSS</b>	<b>MFP</b>	<b>RBMC</b>	<b>HFC</b>	<b>RABA</b>	<b>PHAP</b>	<b>VM</b>

**NB:** New builds  
**RL:** Retail lending  
**HSS:** Housing support services

**MFP:** Microfinance partnerships  
(HIF & RHF)  
**RBMC:** Residential buildings  
management company  
**HFC:** Housing finance company

**RABA:** Register of apartment  
buildings and apartments  
**PHAP:** Poverty housing alleviation  
platform  
**VM:** Volunteer mobilization

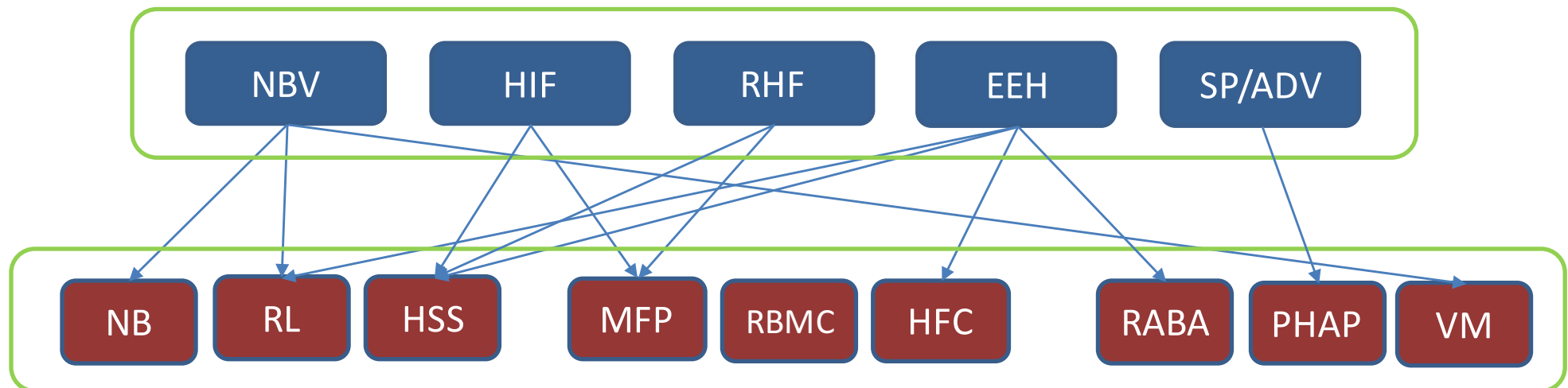

Habitat Macedonia PLOBs	Community Development			Housing Market Development			Housing and Social Development		
	NB	RL	HSS	MFP	RBMC	HFC	RABA	PHAP	VM
<b>KEY PERFORMANCE INDICATORS</b>	Construction Interventions: New			Support market: Households served by financial services			Promote policies and systems: People potentially affected		
	Construction Interventions: Repairs			Support market: Households served by products/services unaccompanied by financial services			\$\$ accessed for adequate housing		
	HSS: General Information			Support market: Capital mobilized - financial services			HSS: General information		
	HSS: Professional services			Support market: Capital mobilized - total value of services			HSS: Training		
							Promote policies and systems: Policies developed		
							Mobilize volunteers: Hours performed		

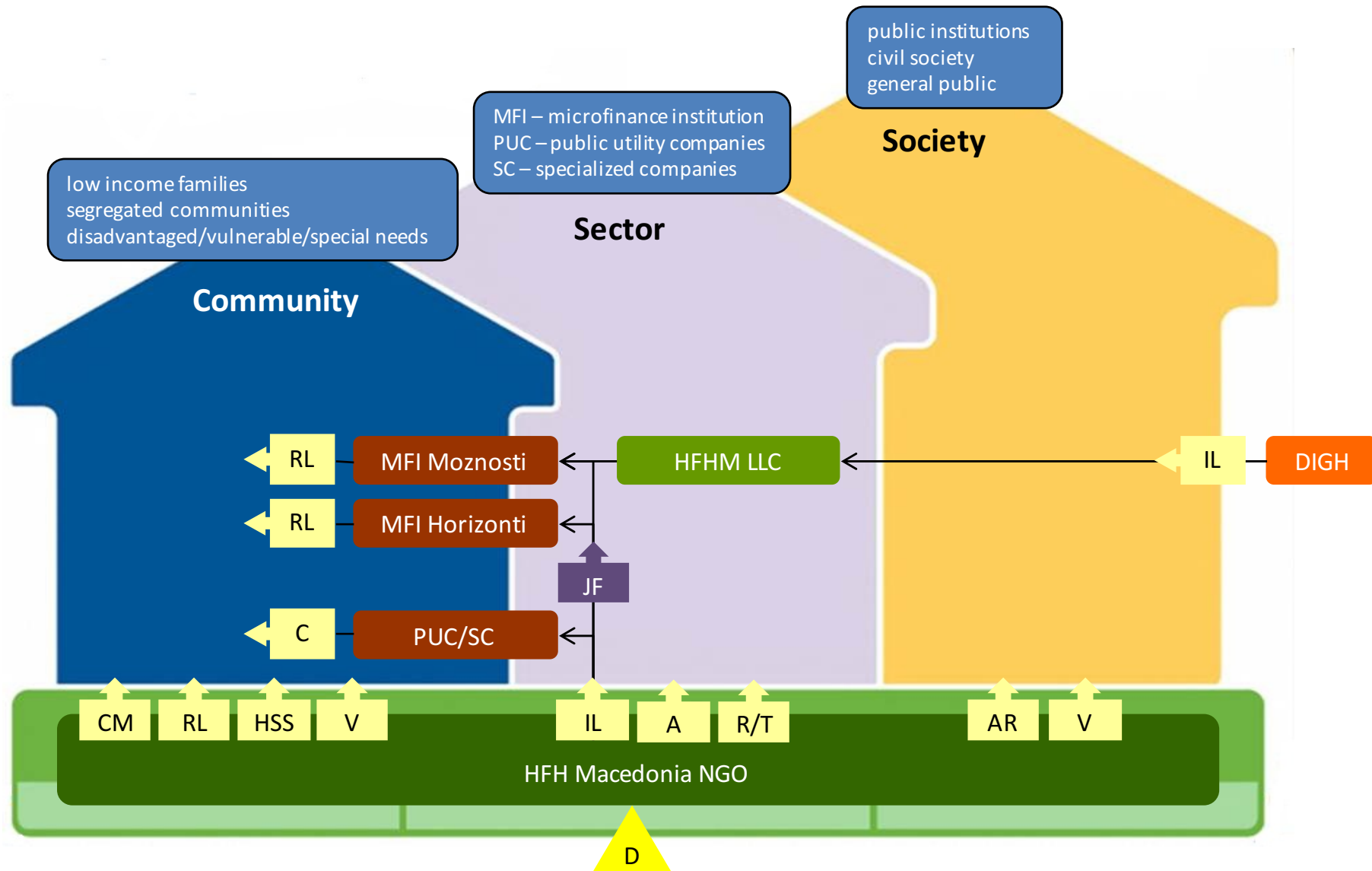

CM – construction management    IL – institutional lending    A – advocacy    AR – awareness raising    V – volunteers  
 RL – retail lending    SS – support services    R/T – research/training    JF – joint funds    D – donations

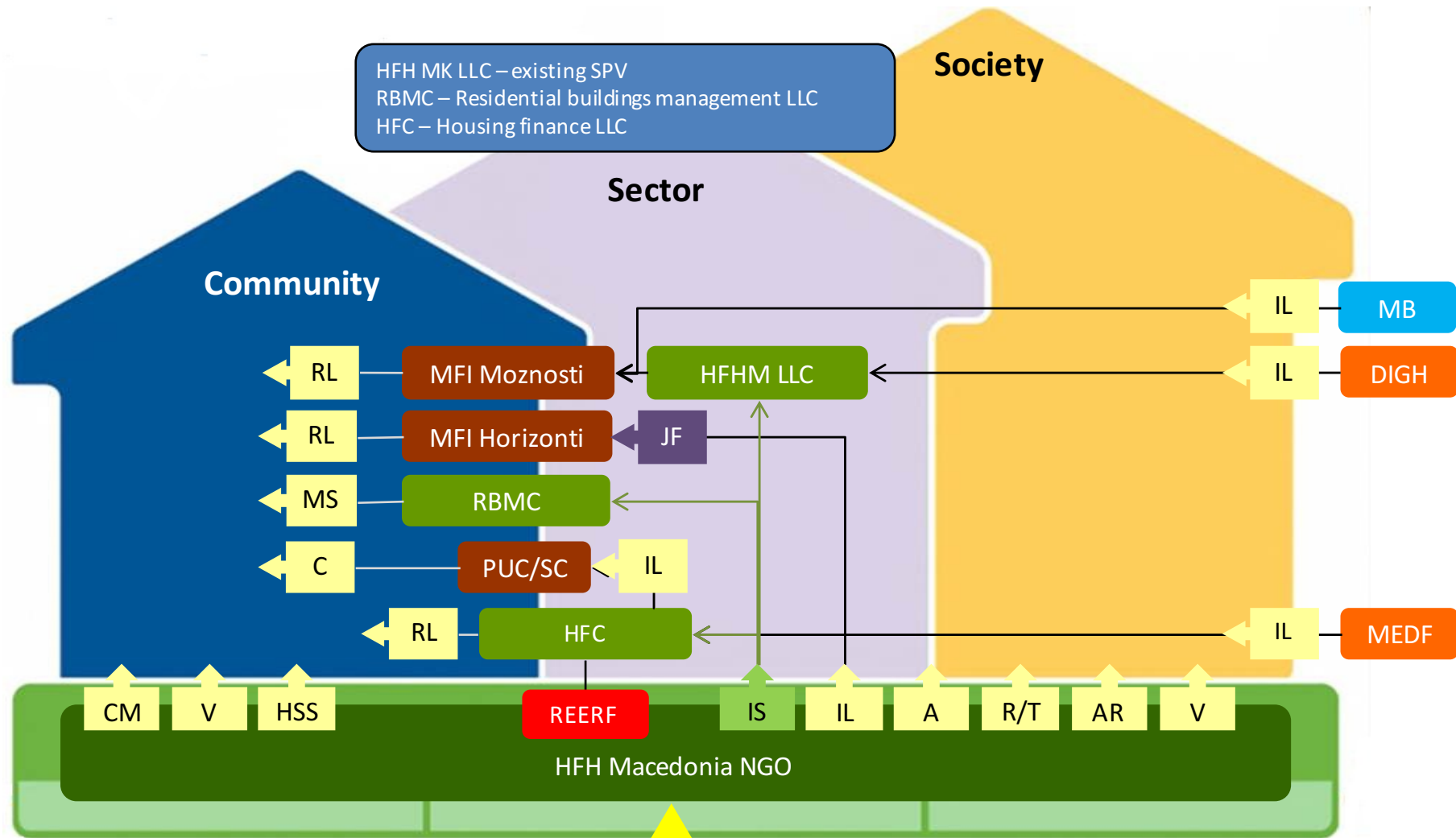

CM – construction management    IL – institutional lending    A – advocacy    AR – awareness raising    V – volunteers    MS – management services  
 RL – retail lending    HSS – housing support services    R/T – research/training    JF – joint fund    IS – institutional support

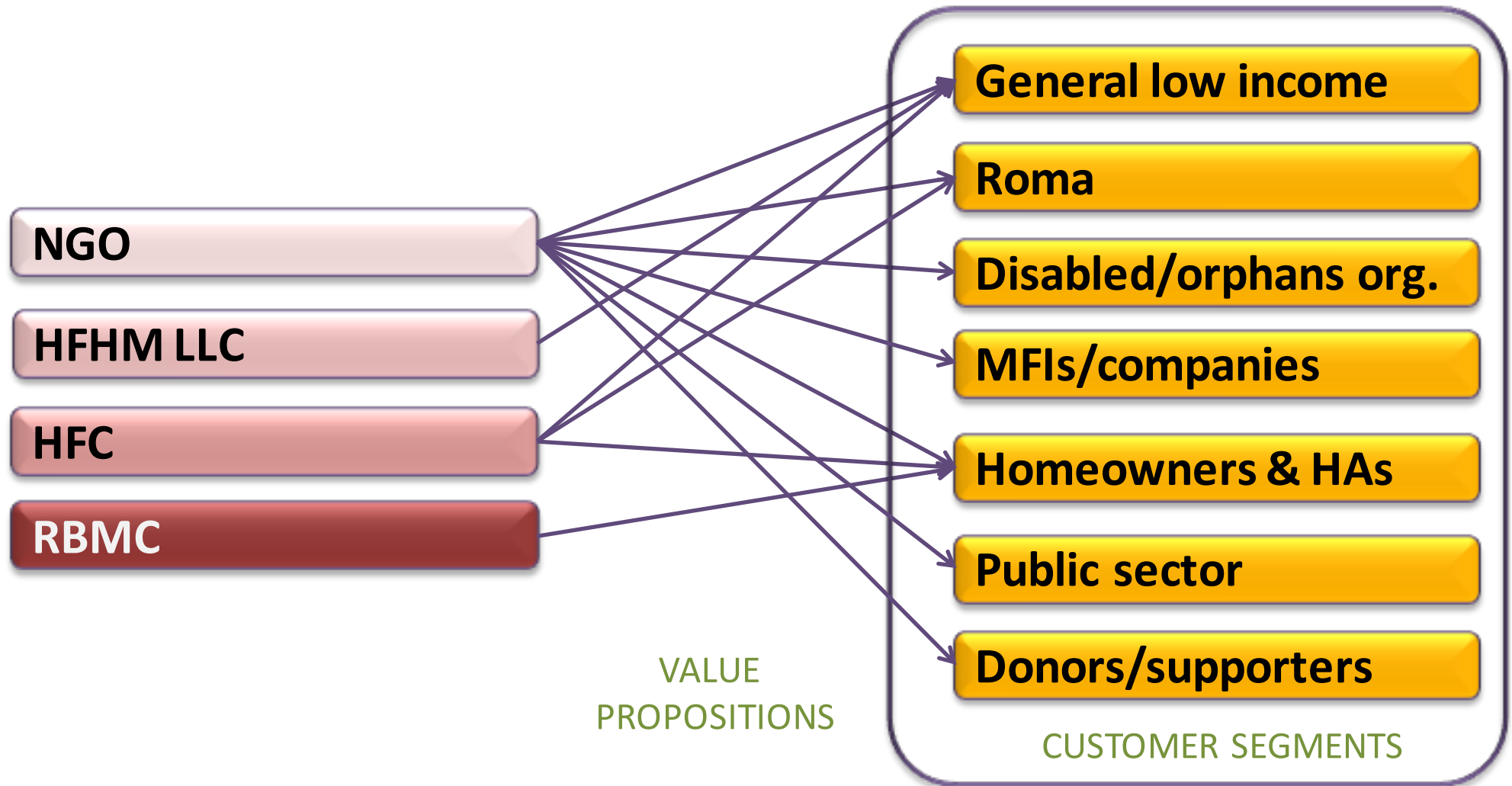

# REVENUE STREAMS

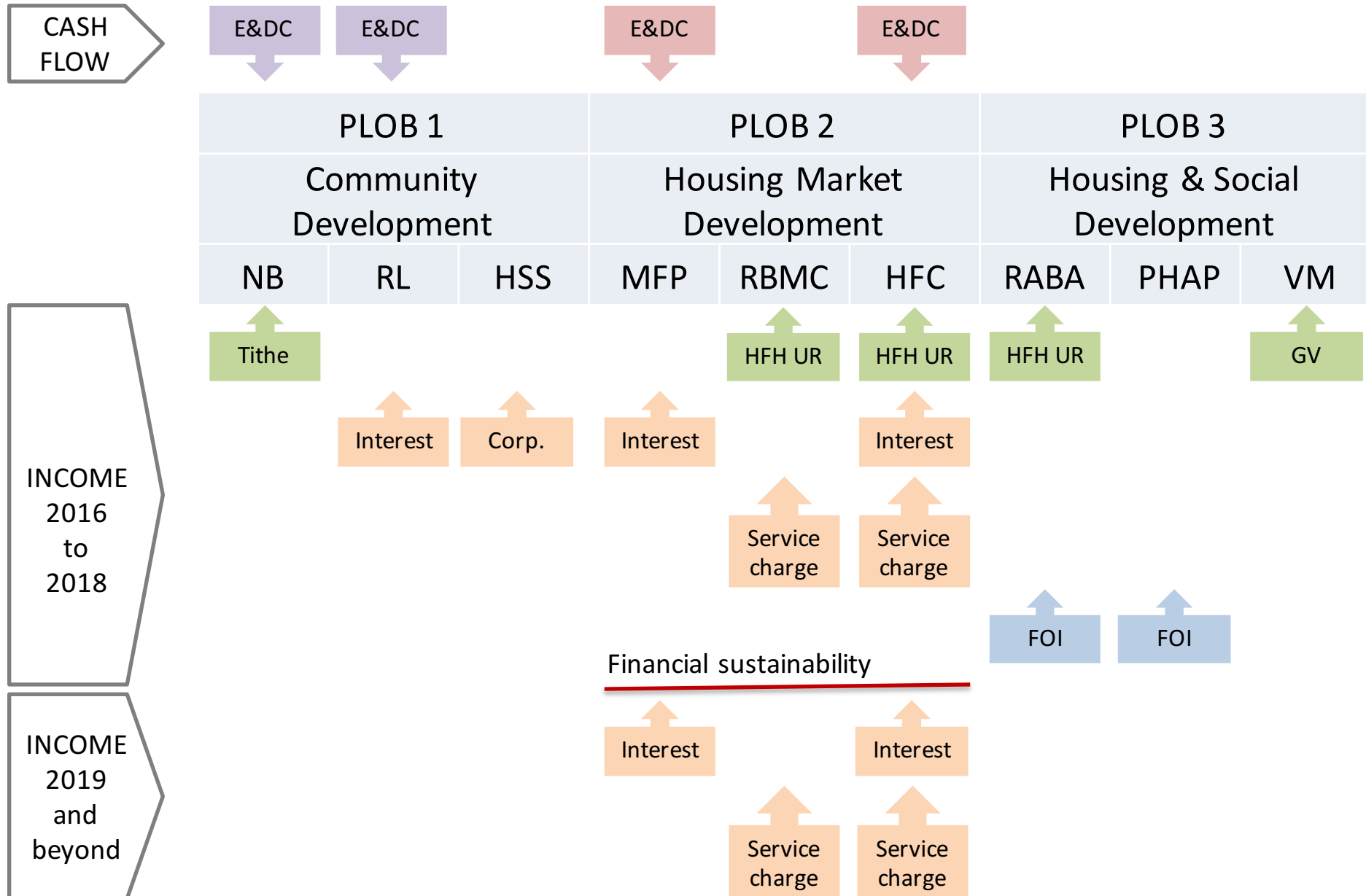

# ORGANIZATIONAL CHART (FY15)

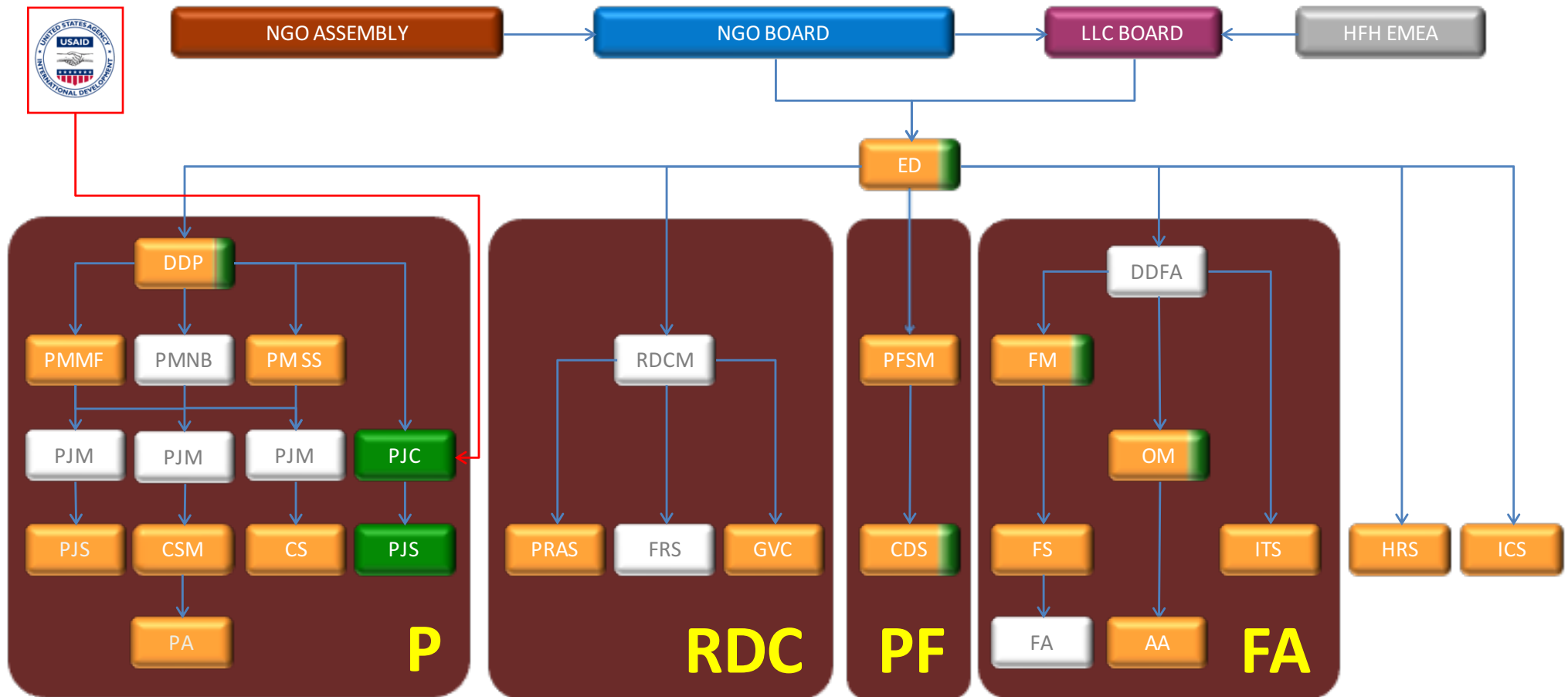



# ORGANIZATIONAL CHART

(by FY18)

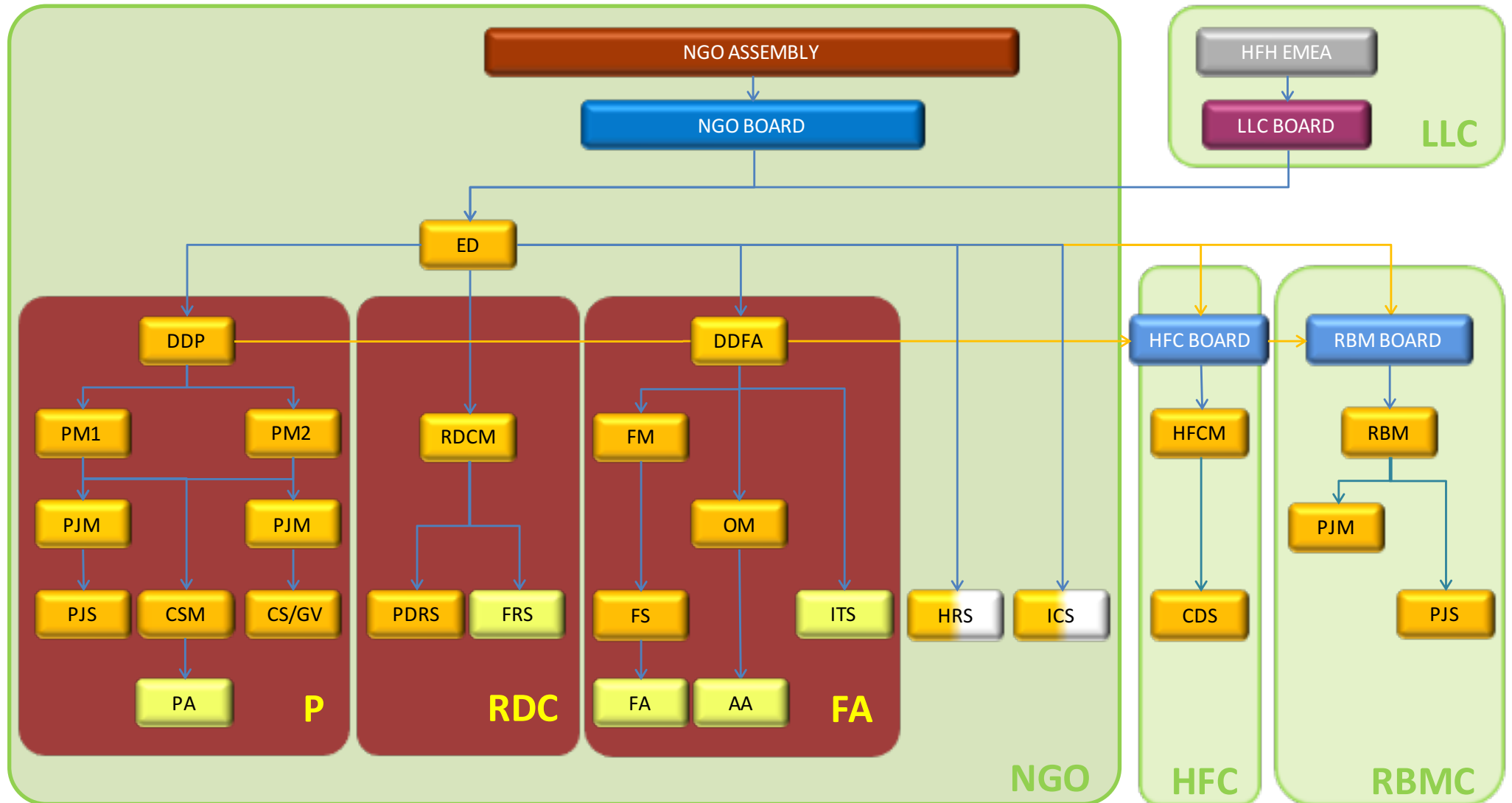

# ORGANIZATIONAL CHART

(as of May 2017)

